

Accuphase

CLASS-A MONOPHONIC POWER AMPLIFIER

A-250

- Pure Class A operation delivers 100 watts of quality power into 8 ohms
- Two totally identical power amplifier units driven in parallel
- 20-parallel push-pull arrangement of MOS-FET devices in output stage delivers linear high power progression to ultra-low 1-ohm impedance
- Input section configured as dual instrumentation amplifier
- Double MCS+ circuit and current feedback topology in amplification stage
- Support for bridged use of two A-250 units for even higher output power
- Strong power supply with massive high-efficiency toroidal transformer and large filtering capacitors





Witness a new dimension of musical expressiveness and bold presence

Ultra-low-noise design with unprecedented S/N ratio of 127 dB brings out a stunning wealth of detail. Semiconductor MOS-FET switches enable output circuitry without any mechanical contacts. Two pure class A power units arranged right and left are driven in parallel to deliver 100 watts into 8 ohms with impeccable quality. A damping factor in excess of 1,000 means that speaker control is nothing less than perfect. The massive A-250 represents a new pinnacle in power amplifier history. Encounter music like never before.

Technology development ahead of the curve

Fully balanced signal paths realized with dual instrumentation amplifier configuration

The A-250 features fully discrete circuit components in a dual configuration employing the latest instrumentation amplifier topology, allowing all signal paths throughout the power amplifier to be fully balanced. This not only eliminates any possible internal sources of noise or distortion as demonstrated by the outstanding performance ratings, it also makes the amplifier highly impervious to changes in ambient conditions. Consequently, operation stability and reliability which are crucial for a power amplifier have been dramatically enhanced.

Double MCS+ (Multiple Circuit Summing) in amplifier stage realizes highest-ever signal/noise ratio in an Accuphase component

The Double MCS+ configuration uses four circuits for amplifying the input signal, connected in parallel to keep distortion to a minimum and to further enhance S/N ratio and other parameters. The resulting level of sound quality is simply stunning.

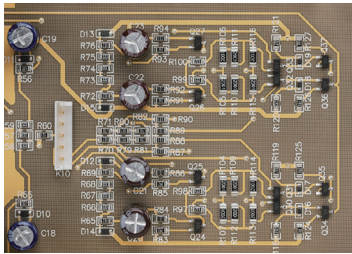

Two totally identical power amplifier units driven in parallel

As shown in the circuit diagram of the amplifier section, the power amplification stage makes use of two completely identical power units, each with 10 N-channel and 10 P-channel power MOS-FETs connected in parallel. These units are arranged on the left and right side of the chassis and driven in parallel, resulting in a 20-parallel configuration. This ensures a stable balance in terms of electrical operation, weight distribution, thermal dissipation and other aspects. The parallel drive approach achieves a total allowable power dissipation value of 5.2 kW, which in turn reduces the power load on each MOS-FET, allowing each device to operate effectively in its range of optimum linearity.

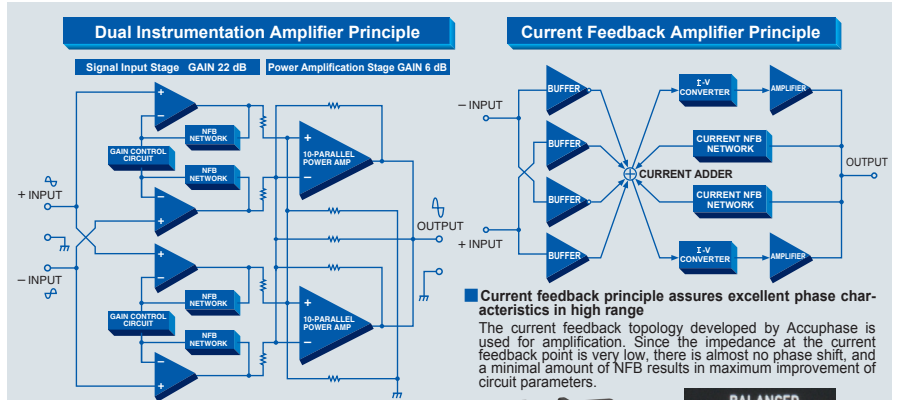

Current feedback principle assures excellent phase characteristics in high range

The current feedback topology developed by Accuphase is used for amplification. Since the impedance at the current feedback point is very low, there is almost no phase shift, and a minimal amount of NFB results in maximum improvement of circuit parameters.

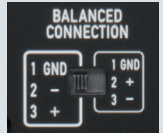

Phase selector for balanced input provides support for either pin 2 ⊖ or pin 3 ⊕ systems.

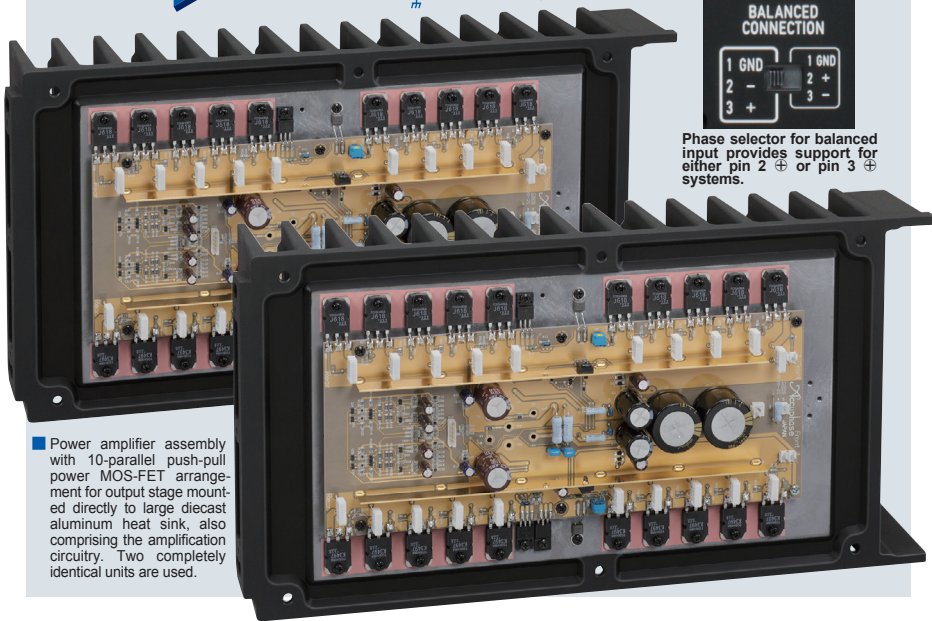

Power amplifier assembly with 10-parallel push-pull power MOS-FET arrangement for output stage mounted directly to large diecast aluminum heat sink, also comprising the amplification circuitry. Two completely identical units are used.

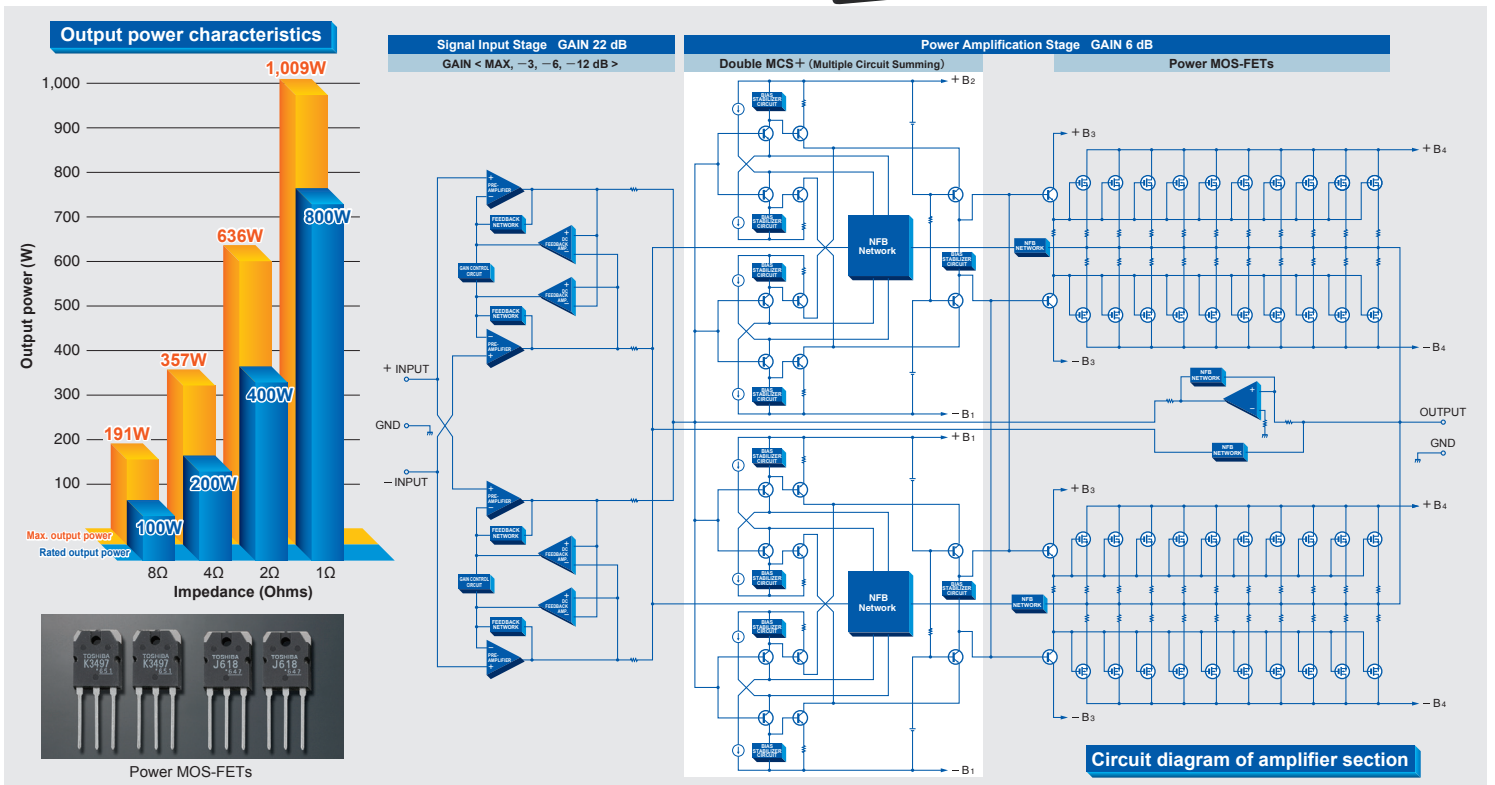

The Pinnacle of Technology



The Beauty of Tradition



Ultra-massive pure Class A monophonic power amplifier

A-250 is built to excel in every respect. Carefully selected exquisite parts and materials are brought together to realize leading-edge technology. Enclosed by the refined champagne gold faceplate and a massive top plate cut from ultra-thick aluminum with a beautiful hairline finish, the amplifier exudes an atmosphere of solid elegance and dependable power.



Advanced Features

- 20-parallel push-pull arrangement of power MOS-FETs delivers linear power progression: 800 watts (music signal) into 1 ohm, 400 watts into 2 ohms, 200 watts into 4 ohms, or 100 watts into 8 ohms.
- Strong power supply with massive high-efficiency toroidal transformer and two large 100,000 μF filtering capacitors.
- Printed circuit boards in power amplifier assembly made from glass cloth fluorocarbon resin with low dielectric constant and minimum loss.
- 4-stage gain selector (MAX, -3 dB, -6 dB, -12 dB) also minimizes residual noise.
- Two sets of oversize speaker terminals accept also spade lugs and banana plugs and allow bi-wiring connection.
- Semiconductor (MOS-FET) switches used for protection circuitry prevent contact problems and ensure long-term reliability. Eliminating mechanical contacts from the signal path also further enhances sound quality.
- Fully balanced input stage shuts out external noise interference.
- OPERATION selector allows use of two A-250 units for bi-amping or bridged operation. Bridging allows upgrade to monophonic amplifier with even higher power, delivering 1,600 watts into 2 ohms (music signal), 800 watts into 4 ohms, or 400 watts into 8 ohms.
- Output level indication switchable between 5-digit numeric readout and 40-point LED bar graph with further improved readability. Hold time selector button also provided.
 - Meter operation on/off switch.
 - Digital power meter showing true power values, based on output current detected by a Hall element.
 - Power meter range selector and auto range function for automatic power tracking.
- Major parts in power supply and signal path are gold-plated.



Digital power meter/bar graph meter



Large high-efficiency toroidal power transformer



100,000 μF filtering capacitors



Gain control selector

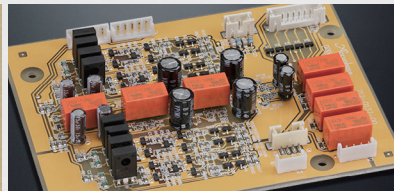

Balanced amplifier assembly

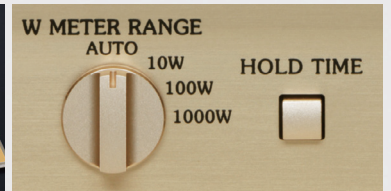

Digital power meter range selector / Hold time selector button



Large gold-plated speaker terminal made of solid brass



MOS-FET switches

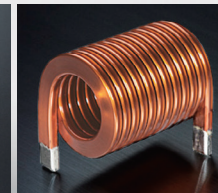

Ultra-heavy-gauge edgewise coil

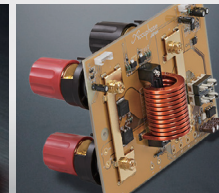

Protection circuit assembly



OPERATION selector



Top plate with hairline finish

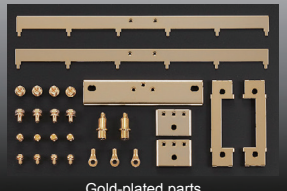

Gold-plated parts



Example for bridged connection

Bridged operation of two A-250 units allows upgrading to a monophonic amplifier with even higher power.

- * For connecting the SPEAKER terminals to each other, use speaker cable of the same grade as for other speaker connections.
- * OPERATION selector of left channel/right channel ① unit: BRIDGE NOR
- * OPERATION selector of left channel/right channel ② unit: BRIDGE REV.

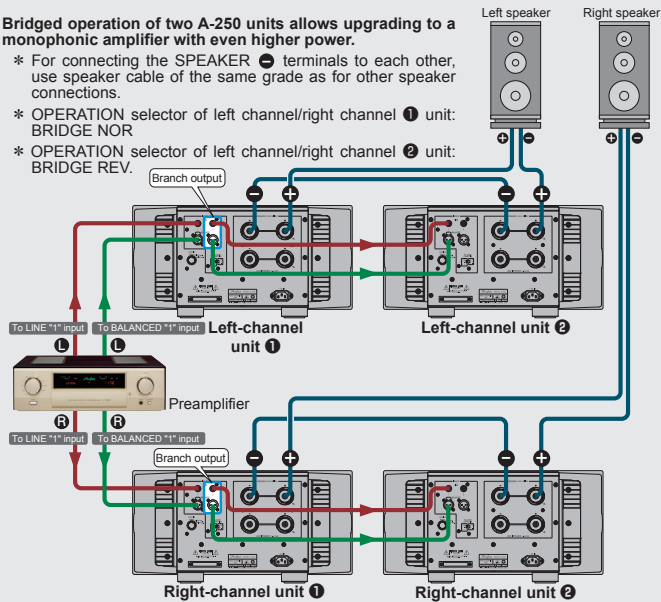

Example for bi-amping connection

In a bi-amped setup, the speaker units for the LOW frequency range and HIGH frequency range are driven by separate amplifiers, for optimum sound quality.

- * The speakers must have a built-in crossover network and separate inputs for LOW and HIGH range.
- * Set the OPERATION selectors of all four units to NORMAL.

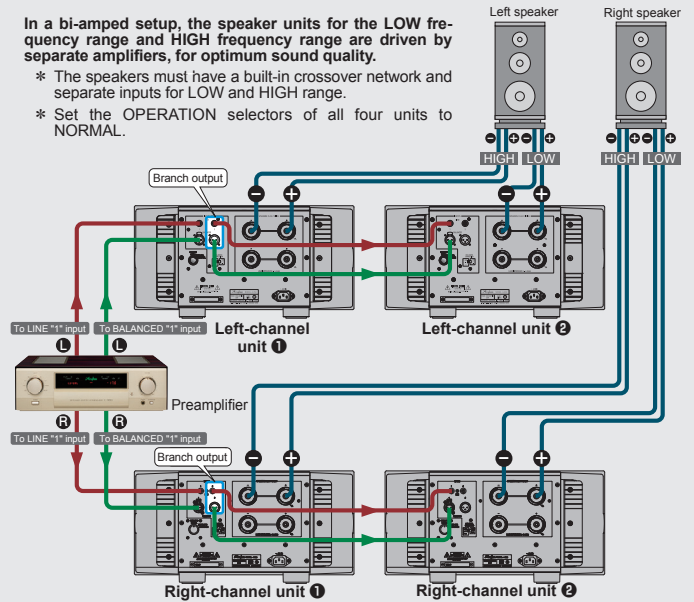

Front panel

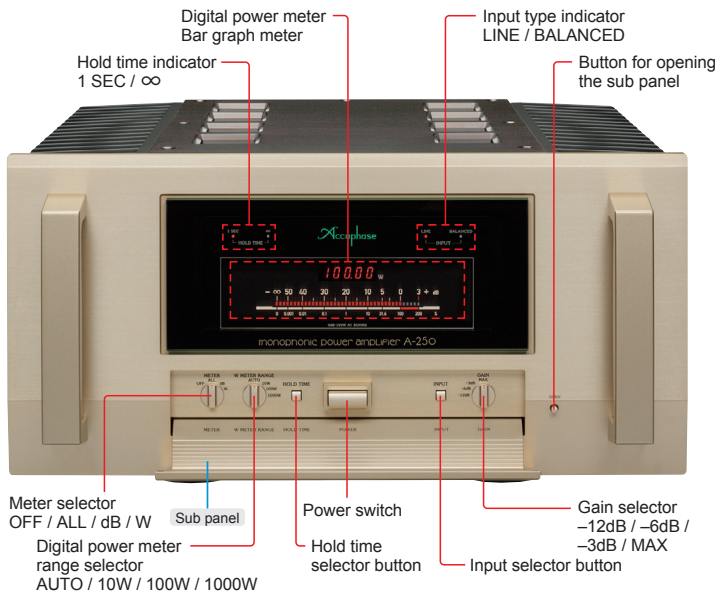

Rear panel

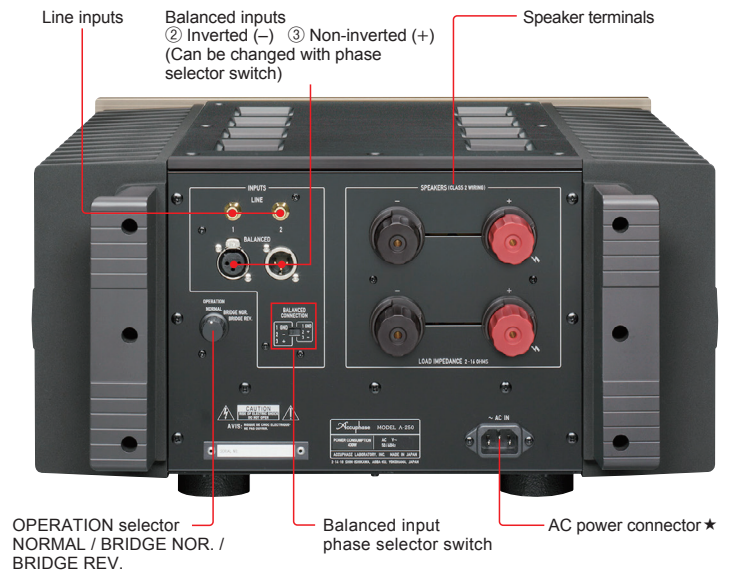

A-250 Guaranteed Specifications [Guaranteed specifications are measured according to EIA standard RS-490.]

Continuous Average Output Power (20 - 20,000 Hz)	Normal mode	800 watts into 1 ohm *1 400 watts into 2 ohms 200 watts into 4 ohms 100 watts into 8 ohms *2
	Bridged mode (2 units)	1,600 watts into 2 ohms *1 800 watts into 4 ohms 400 watts into 8 ohms
Total Harmonic Distortion	0.05%	with a 2-ohm load
	0.03%	with a 4 to 16-ohm load
Intermodulation Distortion	0.01%	
Frequency Response	At rated continuous average output: 20 - 20,000Hz +0 -0.2 dB At 1 watt output: 0.5 - 160,000Hz +0 -3.0 dB	
Gain	28.0 dB (GAIN selector in MAX position)	
Gain Selection	MAX, -3 dB, -6 dB, -12 dB	
Output Load Impedance	Continuous output: 2 to 16 ohms With music signal: 1 to 16 ohms	
Damping Factor	1,000	
Input Sensitivity (with 8-ohm load)	1.13 V for rated continuous average output 0.11 V for 1 watt output	

Notes: (*1) Ratings marked *1 are for music signals only.
(*2) The output range for pure class A operation is 100 W.

Input Impedance	Balanced:	40 kilohms
	Line:	20 kilohms
Signal-to-Noise Ratio (A-weighted, with input shorted)	127 dB (GAIN selector in MAX position) 133 dB (GAIN selector in -12 dB position) At rated continuous average output	
Output Level Meter	Digital power meter 5-digit indication showing true power (W) Range selection AUTO / 10 W / 100 W / 1,000 W Bar graph meter Represents output voltage values (dB) using 40 points Peak hold time 1 second / ∞ (infinite) selectable * Display off switch provided	
Power Requirements	120/220/230 V AC, 50/60 Hz	
Power Consumption	300 watts idle 430 watts in accordance with IEC 60065	
Maximum Dimensions	Width	465 mm (18.31)
	Height	238 mm (9.37)
	Depth	514 mm (20.24)
Mass	46.0 kg (101.4 lbs) net 55.0 kg (121.3 lbs) in shipping carton	

Remarks

- ★ This product is available in versions for 120/220/230 V AC. Make sure that the voltage shown on the rear panel matches the AC line voltage in your area.
- ★ The 230 V version has an Eco Mode that switches power off after 120 minutes of inactivity.
- ★ The shape of the AC inlet and plug of the supplied power cord depends on the voltage rating and destination country.

Supplied accessories
● AC power cord

