

Accuphase

PRECISION STEREO PREAMPLIFIER

C-3900

- Dual Balanced AAVA volume control
- High-gain discrete current feedback type input amplifier
- ANCC technology minimizes noise and distortion
- Newly developed volume sensor construction
- Separate toroidal power transformers for left and right
- Newly developed filtering capacitors
- Separate unit amplifiers for left and right
- Printed circuit boards using glass cloth fluorocarbon resin
- Wood cabinet with natural grain finish
- High-performance headphone amplifier





The culmination of half a century of Accuphase preamplifiers

The Dual Balanced AAVA design with two balanced AAVA circuits delivers sonic excellence that is transparency itself. Volume adjustment is realized while retaining all the vibrant energy and richness of detail that is the life breath of an artistic performance. The supple elegance of music as reproduced by the top-of-the-line C-3900 is a moving experience that reflects the impressive depth of Accuphase know-how.

Innovation - The leading edge of technology

■ Developing a new preamplifier

To celebrate the 50th anniversary of Accuphase's founding, the development of a new flagship model to incorporate the entire wealth of the company's experience was begun. Now, after five years, the work is complete. The C-3900 represents an uncompromising harmony of technology and sensibility, boasting ultimate performance and sound quality that ushers in a new era of the preamplifier.

■ Revolutionary AAVA volume control

Conventional preamplifiers attenuate the input signal by means of resistors and then amplify the result, which invariably leads to an increase in noise. AAVA on the other hand eliminates the entire step of resistor-based input signal attenuation. With this breakthrough principle, direct volume adjustment is performed through a combination of V-I (voltage-current) conversion circuits of different gain. As a consequence, there are no changes in impedance or frequency response and sound quality remains impeccable. Any changes in noise level depending on the selected volume position are kept to an absolute minimum, thereby realizing outstanding S/N ratio also at commonly used listening levels.

■ Dual Balanced AAVA takes AAVA to new heights

In the C-3900, the Balanced AAVA principle which involves two balanced-connection AAVA circuits is further elevated by driving two such units in parallel, resulting in the Dual Balanced AAVA topology with significantly improved electrical characteristics. Compared to previous models, the already excellent noise level is reduced by a further 30 percent.

■ High-accuracy, high-rigidity volume sensor construction

The volume sensor mechanism performs the task of detecting the angular position of the volume knob. Accuphase has developed the volume sensor in-house, using a massive aluminum block extruded and finished with utmost precision. The knob provides an utterly solid and smooth operation feel and achieves extremely accurate position detection. When using the Remote Commander, a motor drives the volume knob via a set of gears. Generally, gears produce a meshing sound when rotating, but this position sensor is designed so that the gears mesh with each other while always maintaining a constant pressure, which enables super quiet and comfortable volume adjustment.

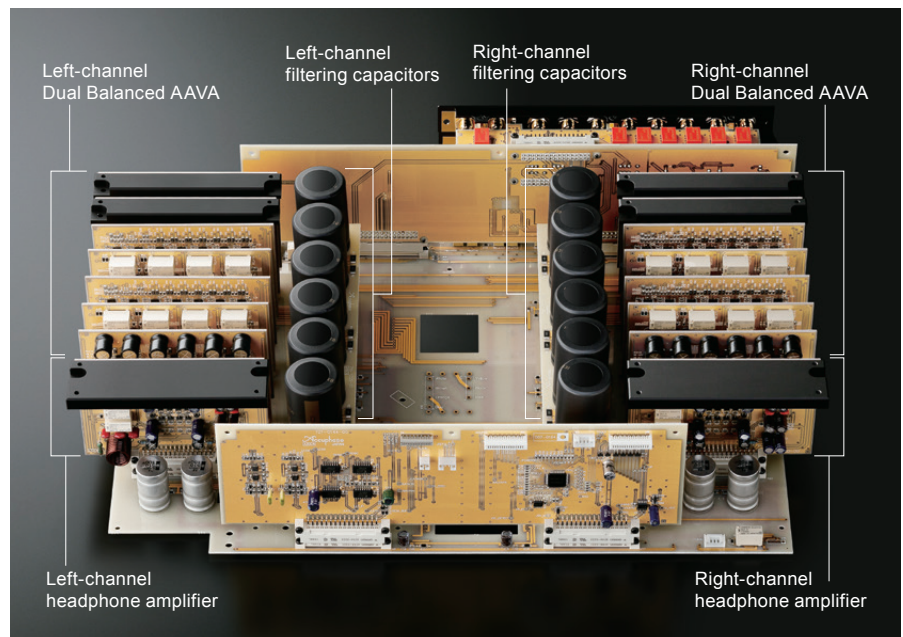
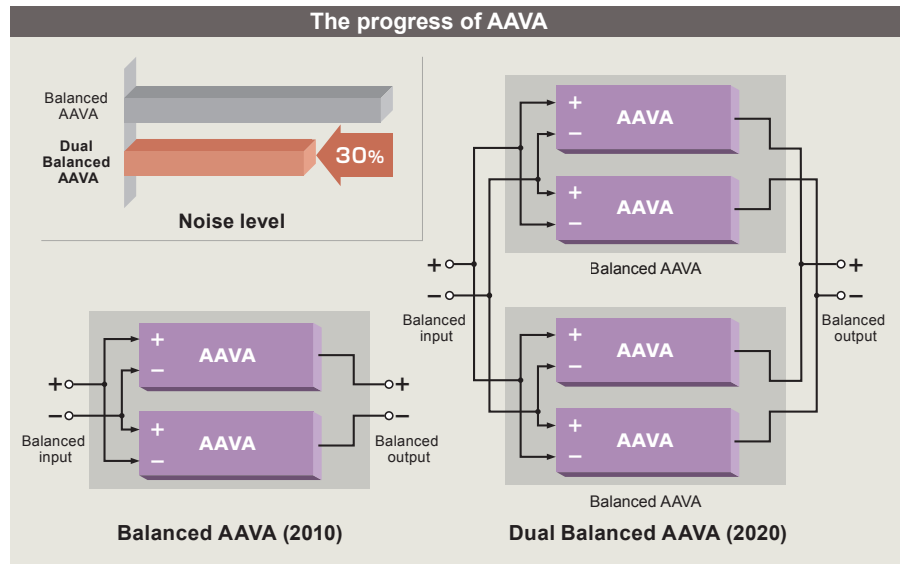
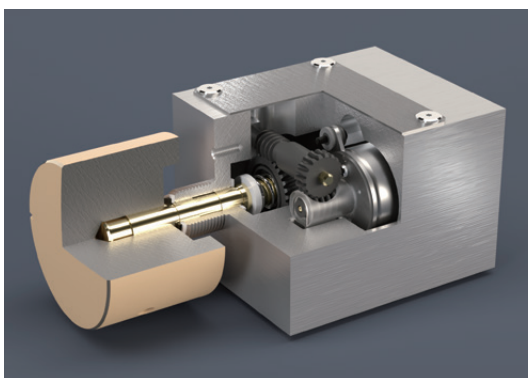

■ Dual Balanced AAVA with separate configuration for left and right channels

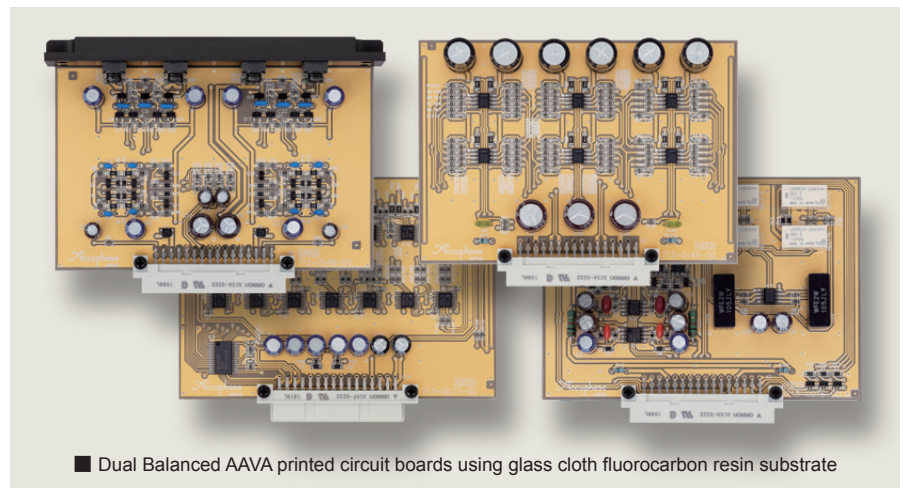

■ Dual Balanced AAVA printed circuit boards using glass cloth fluorocarbon resin substrate

Going to the Limit



—and Beyond



Precision Stereo Preamplifier with Dual Balanced AAVA

Featuring Dual Balanced AAVA topology with two Balanced AAVA circuits driven in parallel, the C-3900 boldly challenges the limits of performance and leaves conventional notions far behind. Step up to a new sound stage such as never experienced before.



Advanced features

- Newly developed Dual Balanced AAVA volume control
- High-gain discrete-configuration current feedback type input amplifier
- ANCC (Accuphase Noise and Distortion Cancelling Circuit) technology minimizes noise and distortion
- Dedicated headphone amplifier uses power transistors in the parallel push-pull output stage to ensure optimal sound quality for private listening
- Logic-controlled relays for signal switching assure high sound quality and long-term reliability
- Printed circuit boards for signal transmission are made from glass cloth fluorocarbon resin with low dielectric constant and minimum loss
- Separate left and right power supply units with toroidal power transformers and a total of twelve 10,000 μF filtering capacitors
- Newly developed volume sensor construction for utterly smooth and quiet operation feel
- Versatile arrangement of inputs and outputs (seven line level inputs, four balanced inputs, and two sets of line level and balanced outputs)
- Line input and output connectors for a recorder
- Line level and balanced EXT PRE inputs for connection of an external preamplifier
- Individual phase setting for each input
- Switchable overall gain (12 dB / 18 dB / 24 dB)
- Left / right balance control also realized with Dual Balanced AAVA
- Stereo signal can be switched to monophonic operation
- -20 dB volume attenuator
- Loudness compensator for correcting the perceived spectral balance
- Informative and easy to read input and volume level indication with on / off switching
- Elegant champagne gold front panel and massive wood cabinet with natural grain finish
- "High Carbon" cast iron insulator feet with superior damping characteristics



- 1 Output selector for using an external preamplifier and controlling output operation
- 2 Gain selector for overall system gain
- 3 Left / right balance control knob
- 4 Loudness compensator for correcting the perceived spectral balance
- 5 Headphone level selector for switching headphone amplifier gain
- 6 Display button to switch on / off the input and volume indication
- 7 Phase selector button for input signal
- 8 Button for switching stereo signals to a monophonic signal
- 9 Recorder selector for function switching when a recorder is connected

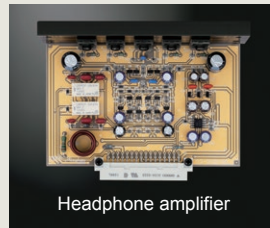

Headphone amplifier

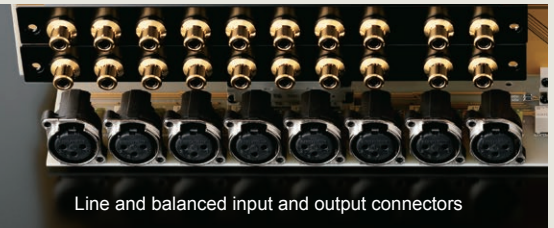

Line and balanced input and output connectors



Filtering capacitors



Toroidal power transformers



- **Supplied Remote Commander RC-250**
Allows volume adjustment, input source switching etc.



Recommended product

■ By connecting the Stereo Phono Amplifier C-47, high-quality reproduction of analog records becomes possible.



Stereo Phono Amplifier C-47

- Low-noise fully balanced configuration
- One dedicated balanced MC phono input and three sets of regular phono inputs
- Balanced and line level output connectors
- Separate settings memory for each input position



Phono cartridge	Input impedance (ohms)	Gain (dB)
MC	10/30/100/ 200/300/1k	64/70
MM	1k/47k/100k	34/40

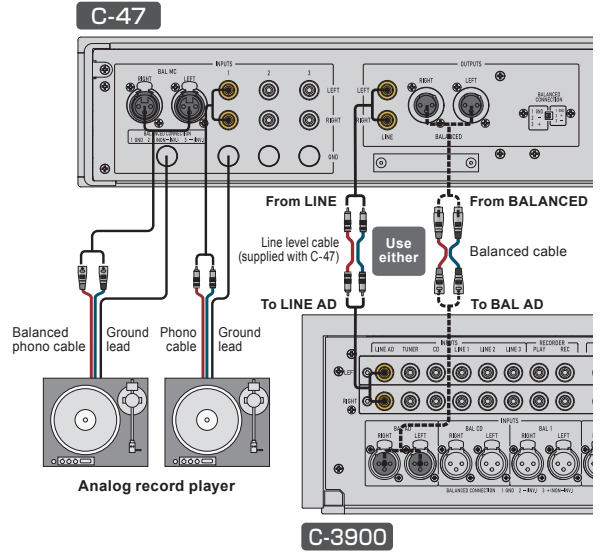

Front Panel

Input selector, Display, Input display section, Remote sensor, Level display section, Volume control knob, Power switch, OPEN button, ATTENUATOR button, Headphone jack.

* For information on controls in the sub panel area, please see the preceding page.

Rear Panel

Line input connectors LINE AD / TUNER CD / LINE 1, 2, 3, RECORDER connectors PLAY / REC, Line output connectors LINE 1 / LINE 2, Balanced output connectors BAL 1 / BAL 2, Balanced input connectors BAL AD / BAL CD / BAL 1, 2, External preamplifier input connectors BAL, AC power supply connector*, External preamplifier input connectors LINE.

C-3900 Guaranteed Specifications [Guaranteed specifications are measured according to EIA standard RS-490.]

Frequency response	BALANCED / LINE INPUT	3 – 200,000 Hz +0 -3.0 dB 20 – 20,000 Hz +0 -0.2 dB			
Total Harmonic Distortion	All input connectors	0.005%			
Input sensitivity, Input impedance	Input connector	Input sensitivity		Input impedance	
		For rated output	For 0.5 V output		
	BALANCED	252 mV	63 mV	40 kilohms (20 / 20 kilohms)	
	LINE	252 mV	63 mV	20 kilohms	
Rated output voltage, Output impedance	BALANCED / LINE OUTPUT	2 V 50 ohms			
S/N ratio, Input-converted noise	Input connector	Input shorted (A weighting)		S/N ratio (EIA)	
		BALANCED	S/N ratio at rated output		Input-converted noise
			118 dB		-130 dBV
LINE	118 dB	-130 dBV	112 dB		
Max. output level (20 – 20,000 Hz)	BALANCED / LINE OUTPUT		7.0 V		
	RECORDER REC		6.0 V		
Max. input voltage	BALANCED INPUT		6.0 V		
	LINE INPUT		6.0 V		

Minimum load impedance	BALANCED / LINE OUTPUT	600 ohms
	RECORDER REC	10 kilohms
Crosstalk	-90 dB / 10 kHz	
Gain (GAIN selector at 18 dB) *Except for REC output, ±6 dB switching is possible	BALANCED INPUT → BALANCED OUTPUT	18 dB
	BALANCED INPUT → LINE OUTPUT	18 dB
	LINE INPUT → BALANCED OUTPUT	18 dB
	LINE INPUT → LINE OUTPUT	18 dB
	BALANCED / LINE INPUT → RECORDER REC	0 dB
Loudness compensator button	1: +2 dB (100 Hz), 2: +4 dB (100 Hz), 3: +6.5 dB (100 Hz)	
Headphone jack	Suitable impedance	8 ohms or higher
	Output level	2 V (40 ohms)
	Gain (LOW, MID, HIGH)	MID reference ±10 dB
Attenuator	-20 dB	
Power requirements	120 V, 220 V, 230 V AC (voltage as indicated on rear panel), 50 / 60 Hz	
Power consumption	47 W	
Maximum dimensions	Width 477 mm (18.78") x Height 156 mm (6.14") x Depth 412 mm (16.22")	
Mass	Net	24.6 kg (54.2lbs)
	In shipping carton	32 kg (71 lbs)

Remarks

- ★ This product is available in versions for 120/220/230 V AC. Make sure that the voltage shown on the rear panel matches the AC line voltage in your area.
- ★ 230 V version has an Eco Mode that switches power off after 120 minutes of inactivity.
- ★ The shape of the plug of the supplied AC power cord depends on the voltage rating and destination country.

Supplied accessories

- AC power cord
- Audio cable with plugs ASL-10B
- Remote Commander RC-250
- Cleaning cloth



ACCUPHASE LABORATORY, INC.